



# 焊接滾輪組

# CMSA Series

## Welding Roller / Pipe Roller

- 適合大型桶槽製作、焊接圓周、切斷作業使用。
- 自動焊接可搭配十字架使用、提昇焊道品質。
- 10T 以上動力以 DC 馬達做驅動力提高旋轉扭力。
- 鋼性強化結構防止機台經荷重而變形。
- 轉速 100~1000 (mm/min)
- It's suitable for big tank making, circumference welding and cutting.
- Automatic welding can work with the cross arm to upgrade the welding path's quality.
- Over 10 tons is driven by DC motor to increase the rotating torque.
- Rigid structure can prevent machine from deforming due to heavy load.
- Rotating speed 100~1000 (mm/min).

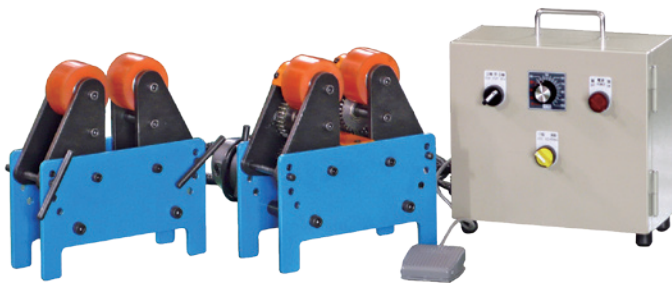

**CMSA-500K** Max. load 最大荷重: **0.5T**

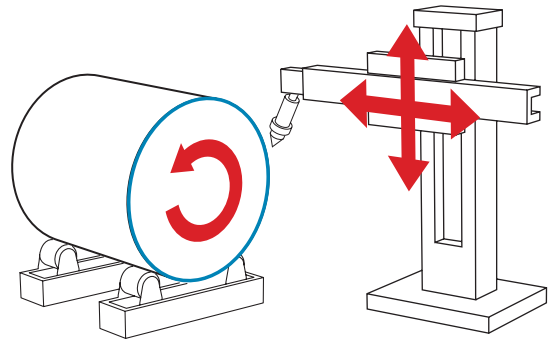

**CMSA-3TD** Max. load 最大荷重: **3T**



**CMSA-5TD** Max. load 最大荷重: **5T**



**CMSA-10TA** Max. load 最大荷重: **10T**



**CMSA-50TC** Max. load 最大荷重: **50T**

型號 Model No	最大旋轉荷重 Max. Rotating load	工件直徑 mm Diameter of workpiece	輪距調整 Wheel distance adjustment	動力 Power	驅動 Transmission	動輪直徑 Diameter of driving wheel	入力電源 Input Power
CMSA-500K	500 kg	Ø 35~350	插梢式 Pin-inserting type	DC	雙輪 Twin-wheel	Ø 70	110V 1Ø
CMSA-3TD	3,000 kg	Ø 50~2000		DC	單邊傳動 Unilateral-transmis	Ø 200	220V 1Ø
CMSA-5TD	5,000 kg	Ø 200~2000		DC		Ø 250	220V 3Ø
CMSA-10TA	10,000 kg	Ø 400~3000		DC	雙輪 Twin-wheel	Ø 270	220V 3Ø
CMSA-20TA	20,000 kg	Ø 400~3500		DC		Ø 300	220V 3Ø
CMSA-30TA	30,000 kg	Ø 400~4000		DC		Ø 350	220V 3Ø
CMSA-10TC	10,000 kg	Ø 1000~3000	自動對位 Automatic Positioning	DC	4輪同動 4-wheel Synchronization	Ø 250	220V 3Ø
CMSA-30TC	30,000 kg	Ø 1000~3000		DC		Ø 300	220V 3Ø
CMSA-50TC	50,000 kg	Ø 1500~4500		DC		Ø 350	220V 3Ø